



Lock Monitoring Box

MSB62-10 MKII



The global standard in
security hardware solutions



Lock Monitoring Box

MSB62-10 MKII

The original & the best. The 1st SCEC endorsed lock monitoring box.

The **Lock Monitoring Box** is designed to monitor lock and door status that can be used as part of an intrusion alarm system or other monitored instrumentation or building management system. The product can be used in a diverse range of applications which include, but are not limited to, securing rooms by monitoring door or lock latch or bolt position.

It incorporates an off set face plate and plunger microswitch that, when coming into contact with a lock, can alert a central monitoring station that the lock mechanism has engaged. For added security it houses a tamper switch that activates when the side cover is removed preventing unauthorised access to the end of line module.



KEY FEATURES

- Ease of installation
- Removable side cover for easy access to EOLM (End of Line Module)
- 4mm thick Faceplate for strength and durability

APPLICATIONS

- Secure rooms to monitor lock functionality
- Fits all 'end of line' modules
- Trigger camera and alarm activation
- For use in building management systems (BMS)

DIMENSIONS

- Body: 96mm long x 22mm wide x 70mm deep
- Face plate: 4mm thick x 178mm long x 28mm wide

COMPATIBILITY

- Compatible with MOST square bolt type deadlocks
- Will retro-fit most mortice lock striker plate

TECHNICAL SPECIFICATIONS

The microswitch function is within the limits of normal manufacturing capabilities. The Lock Monitoring Box come supplied with one change over contact that can be used for multiple applications. Standard security wiring applies depending on the installation system and requirements.

INSTALLATION

- Can be installed in steel, aluminium or wooden frames.

CONSTRUCTION

- Mild steel box
- Seam welded
- Removable side for access
- 4mm Stainless steel face plate

COMPONENTS

- Includes plunger microswitch and tamper switch
- Incorporates high tensile screws to secure face plate

LOCK MONITORING BOX - MSB62-10 MKII

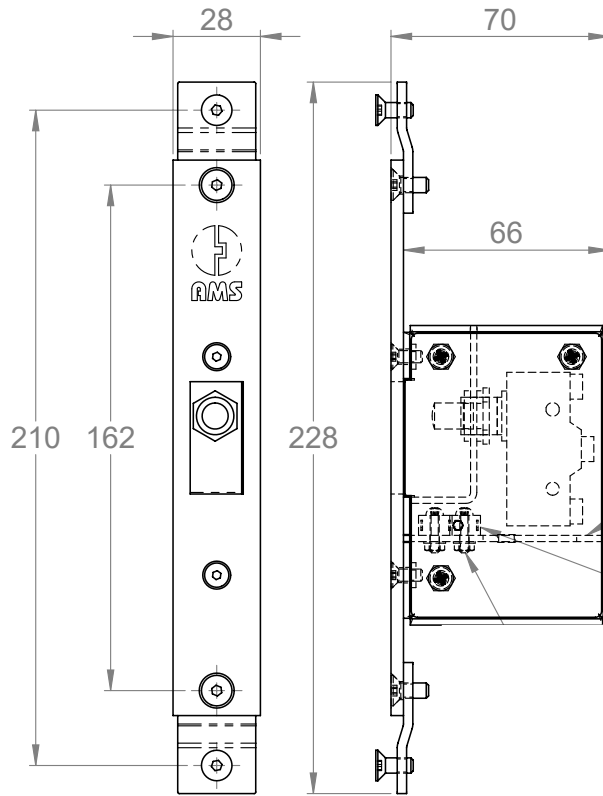

Plunger

Cont. rating	480VAC, 280VDC, 15A
Mech. Life	>10 ⁷ operations
Temp. range	55°C to +85°C (TBC)

Lever Arm

Cont. rating	250VAC 5A resistive 3A inductive
Mech. Life	10 ⁶ operations
Temp. range	55°C to +120°C (TBC)

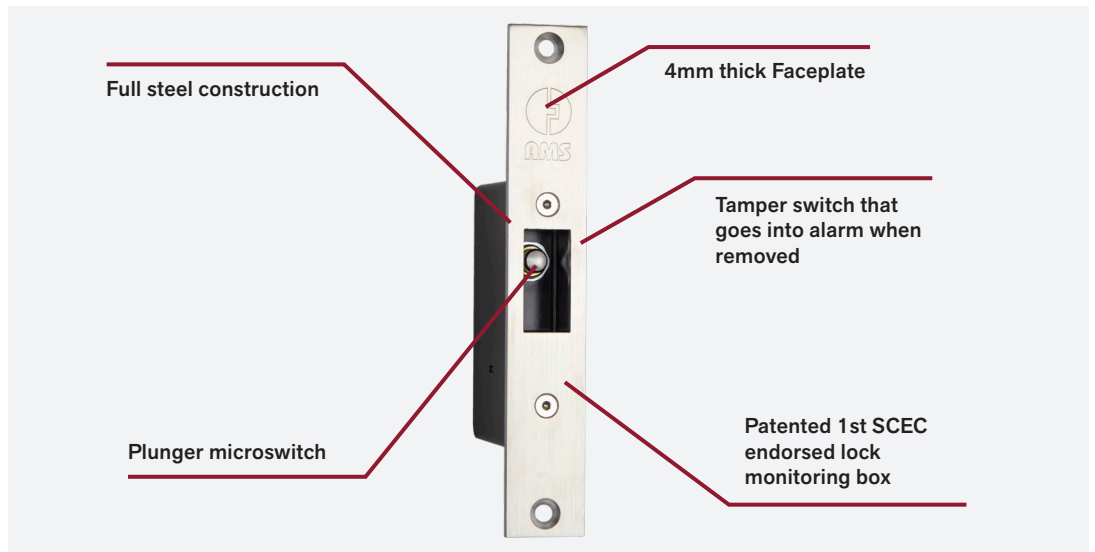

MSB62-10 MKII - Lock Monitoring Box

ASSOCIATED COMPONENTS

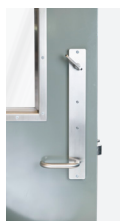

Dual Lock Lever Handle

DLLH 33 Series
Designed and developed exclusively for single lever action.



Dual Lock Lever Handle

DLLH 54
1st lever lock swing bolt combination to work on narrow style frames.

HOW TO ORDER

Product Code	Product Finish	Product Description
MSB62-10 MKII	Mild steel	Lock Monitoring Box



**The global standard
in security hardware
solutions**

We design and manufacture a range of security products that are compatible with existing lock and door furniture.



AMS AUSTRALIA PTY LTD
5/9 & 6/9 Brookes Street,
Mitchell ACT 2911
T: +61 2 6262 2100
E: info@amsaustralia.com.au
www.amsaustralia.com.au